

ROOMWEAVER: A DIGITAL WAVEGUIDE MESH BASED ROOM ACOUSTICS RESEARCH TOOL

Mark J. Beeson and Damian T. Murphy

Media Engineering Group, Dept. of Electronics
University of York, Heslington, York, UK, YO10 5DD
mjb128@ohm.york.ac.uk, dtm3@ohm.york.ac.uk

ABSTRACT

RoomWeaver is a Digital Waveguide Mesh (DWM) based Integrated Development Environment (IDE) style research tool, similar in appearance and functionality to other current acoustics software. The premise of RoomWeaver is to ease the development and application of DWM models for virtual acoustic spaces. This paper demonstrates the basic functionality of RoomWeaver's 3D modelling and Room Impulse Response (RIR) generation capabilities. A case study is presented to show how new DWM types can be quickly developed and easily tested using RoomWeaver's built in plug-in architecture through the implementation of a hybrid-type mesh. This hybrid mesh is comprised of efficient, yet geometrically inflexible, finite difference DWM elements and the geometrically versatile, but slow, wave-based DWM elements. The two types of DWM are interfaced using a KW-pipe and this hybrid model exhibits a significant increase in execution speed and a smaller memory footprint than standard wave-based DWM models and allows non-trivial geometries to be successfully modelled.

1. INTRODUCTION

Architects and composers have long known the dramatic gravitas that can be imposed upon music or spoken word through the creative use of acoustic spaces. This has been exploited for hundreds, if not thousands of years in places of worship and great concert halls by composers such as Mozart, Berlioz and Mahler. In more modern times the psychoacoustic cues that impart this sense of space are usually generated by sound engineers to give an acoustic image that differs from the listening environment into which the sound is actually delivered. Such techniques are often used in theatre, cinema and more recently, interactive multimedia applications and give the composer/audio engineer/sound designer the artistic freedom to place the sound source and listener where required with absolute and complete control.

Acousticians, engineers and practitioners have sought to better understand the underlying physical principles that govern the behavior of sound in an enclosed space. This knowledge, when combined with modern computing techniques has yielded numerous models that aim to synthesize a RIR suitable to impart the notion of a particular acoustic environment upon an anechoic (or *dry*) sound. These techniques can be traced back to simple electro-mechanical devices, the first digital feedback networks, right through to the modern techniques described below.

One option for acquiring RIRs is to make a direct measurement in the desired space although this can be both time

consuming and logistically difficult. The other option (which is the only possibility if the RIR of a virtual space is required) is to use a computational model to produce a virtual RIR that is an accurate analogy of the equivalent real-world space.

Geometrical acoustic techniques are the most popular solution for virtual space modelling with current architectural acoustics programs [1], [2] making use of hybrid image-source [3], ray-tracing [4] and beam tracing [5] techniques to derive RIRs as well as other more general acoustic properties. This is achieved by calculating a sufficient proportion of all the possible propagation paths that exist between a sound source and receiver through the geometric interaction of a *sound-ray* and the surfaces present in the model. Although these techniques produce RIRs appropriate for a digital implementation using delay lines, ray-tracing techniques have a number of limitations. The discrete, clearly defined reflection patterns that result from these geometrical methods have to be convolved with HRTF data in order to make them suitable for auralization purposes and they do not take into account wave interference effects. As such, these geometric methods are valid for high frequencies only and are less appropriate for low frequencies where the wave based properties of sound propagation and the presence of sparsely distributed modal frequencies tend to dominate. They are further limited in their ability to successfully model diffraction effects and hence by extension, sound occlusion due to objects being present in the propagation path, resulting in potential spatialisation errors. The rays used in ray-tracing have no cross-sectional area, whereas the rays used in beam-tracing are often conical or tetrahedral in shape and expand in area as they travel away from the sound source. This allows greater geometrical coverage than ray-tracing for the same number of rays or beams, resulting in quicker detection of valid source-receiver paths.

Finite Element Models and Boundary Element Models offer iterative methods for calculating the resonant frequencies present within an enclosed space. Although accurate these methods are computationally intensive, depending on dense mesh structures to produce results across the audible spectrum. These techniques have been used to create RIRs of virtual spaces [6], but alternative modelling techniques that produce equally valid results with less computational overhead and greater flexibility in terms of implementation and realization are currently more common. One such method uses the multi-dimensional digital waveguide mesh (DWM) and this paper introduces a new research tool based on this algorithm and is laid out as follows. Section 2 introduces the basic concept of the DWM and summarizes some of its limitations. Section 3 presents the RoomWeaver DWM modelling tool and describes how it defines a bounded geometry and

populates it with a mesh structure. The extensible and open-ended design of RoomWeaver is demonstrated in Section 4 through the introduction of a new efficient 2D mesh-type based on the KW-pipe. Results based on the use of this new mesh-type are then presented demonstrating its validity for RIR generation and its computational efficiency over other mesh structures. Section 5 summarizes the work presented in this paper.

2. THE DIGITAL WAVEGUIDE MESH

Digital Waveguide Mesh models techniques have been shown to be appropriate for simulating the acoustic properties of an enclosed space [7], [8], [9]. Although computationally intensive for large spaces or long reverberation times, wave propagation effects are an inherent part of the implementation [10], requiring no additional computational load, and hence this method seems appropriate for modelling the spatial scattering effects due to architectural features that may be present in an enclosed space.

The digital waveguide mesh is derived from the 1-D digital waveguide used extensively for physical modelling synthesis [11]. Higher dimension mesh structures are constructed using bi-directional delay lines and scattering junctions which act as spatial and temporal sampling points within the modelled space. It is also possible to use different mesh topologies to model the same physical space. Figure 1 shows two such topologies – the tetrahedral mesh and the 3-D rectilinear mesh – both of which can be used to model wave propagation through a 3-D space.

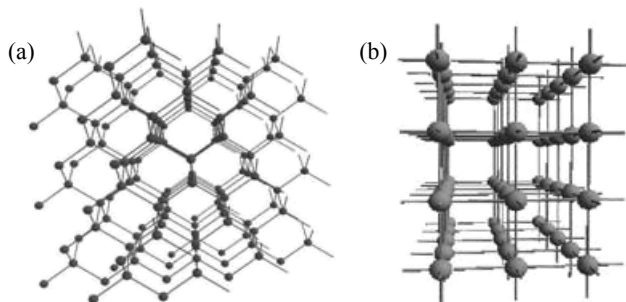

Figure 1: The 3D tetrahedral waveguide mesh (a) and the 3D rectilinear waveguide mesh (b), both of which could be used to model the same 3-D space.

Waveguide mesh models are limited by *dispersion error*, where the velocity of the propagating wave is dependent upon both its frequency and direction of travel, leading to wave propagation errors and a mistuning of the expected resonant modes. The degree of dispersion error is highly dependant upon mesh topology and has been investigated in [12] and can be compensated for to some extent using frequency warping techniques [13]. Current work involves the development of DWM models to deal with frequency and direction dependent reflection at a boundary. Diffusion has yet to be modelled successfully and research into a perfect anechoic boundary shows some promise although they have yet to be implemented with complete success [14].

Perhaps one reason for the lack of perceived awareness of DWM methods in more general room acoustics modelling is that no intuitive software exists for the non-specialist and specialist alike to experiment with. At present the generation of RIRs using DWM models requires meticulous and time consuming editing of

computer code to set up all but the simplest room geometries and mesh topologies. This means that any research scientist wishing to do work in the field has a steep learning curve to overcome as they write and maintain their own code base, making it difficult to quickly try out new ideas and share knowledge. It is for these reasons that the IDE style RoomWeaver research tool was commissioned allowing the user to intuitively set up the geometrical and source/receiver parameters required to generate a RIR by means of a simple Graphical User Interface (GUI). The user may then pick from a variety of mesh topologies and types to generate an appropriate RIR.

Additionally RoomWeaver allows the DWM researcher to develop and test new mesh topologies and types using an extensible plug-in architecture. This system shields the mesh developer from the complexities of the RoomWeaver code base and greatly reduces the time required to develop and test new mesh structures.

3. AN OVERVIEW OF ROOMWEAVER

The current implementation of RoomWeaver (Figure 2) runs on a PC using the Windows operating system and is driven by a platform independent scripting language. This scripting language is used to define all relevant parameters, from the definition of workspaces, projects, room geometry, surface properties, material properties and mesh properties, down to the position and Input/Output attributes of sources and receivers. All of these files observe a similar syntax and standard constructs such as `If-Else` statements and `For-Loops`, and variable manipulation is supported in all script files. This architecture means that a simple command line port of RoomWeaver should be trivial to implement on any platform. Unfortunately the DLL based plug-in system is specific to the Windows platform, so if this aspect is to be transferred across platforms some redesign must be undertaken to achieve platform independency.

3.1. Modelling Rooms using RoomWeaver

RoomWeaver uses a hierarchal approach when organizing the data required to successfully model a room. This data is browsed using the workspace navigator pane in the GUI as shown in Figure 2.

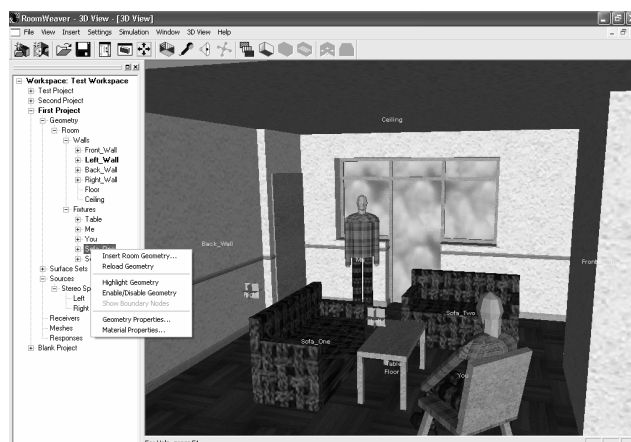

Figure 2: A Screenshot of RoomWeaver showing the 3D View and Workspace navigator

3.1.1. Defining the Geometry

Once a project has been set up it is necessary to define a room geometry. Within RoomWeaver a geometry consists of several surfaces that in turn consist of a series of connected points. These surfaces may be organised into surface groups, allowing geometry to be defined in a logical, hierarchical manner. The rooms must be defined in a text file using RoomWeaver's object-orientated scripting language. The scripting language allows each surface and group to be added individually, but it also caters for *Objects* and *Models*. For instance it is possible to define a *model* of an auditorium chair at only one point in a file and then create several instances or *Objects* of the *model* within the geometry with a single line of text (See Figure 3). The geometry file can also include *Model Libraries* to make the best use of any pre-written models. Models can take input arguments that change their behaviour, and surfaces and groups can be moved, rotated and scaled using the script.

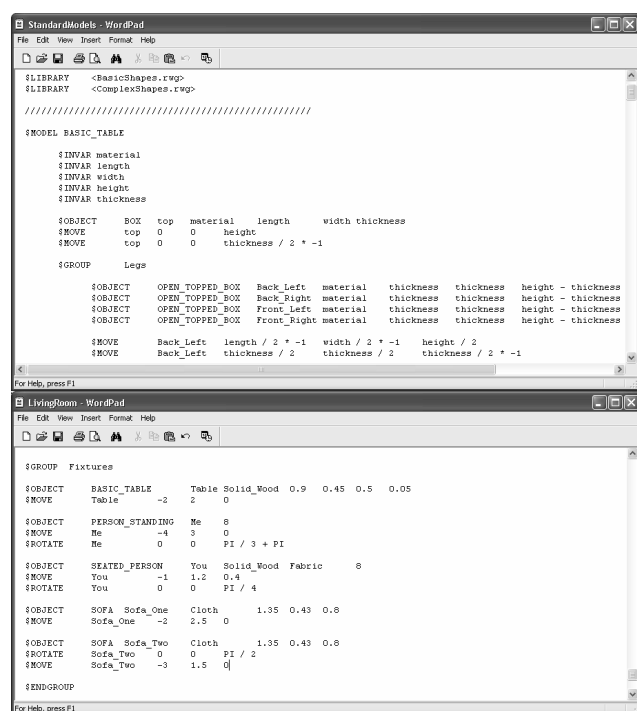

Figure 3: The RoomWeaver geometry scripting language allows the definition of reusable Models that can then be used to simply build more complex spaces.

3.1.2. Manipulating Materials

Materials are assigned to surfaces in the geometry file, but once loaded the materials on the walls can be easily changed and saved as *surface sets*, effectively allowing the same geometry to have several 'outfits'. RoomWeaver includes a library of materials that can be applied to a surface (adapted from the *Odeon* Material Library, downloadable as part of the *Odeon* package from "www.dat.dtu.dk/~odeon/"), the properties of which may be edited and new materials can also be created from within the program. Materials have absorption coefficients for any number

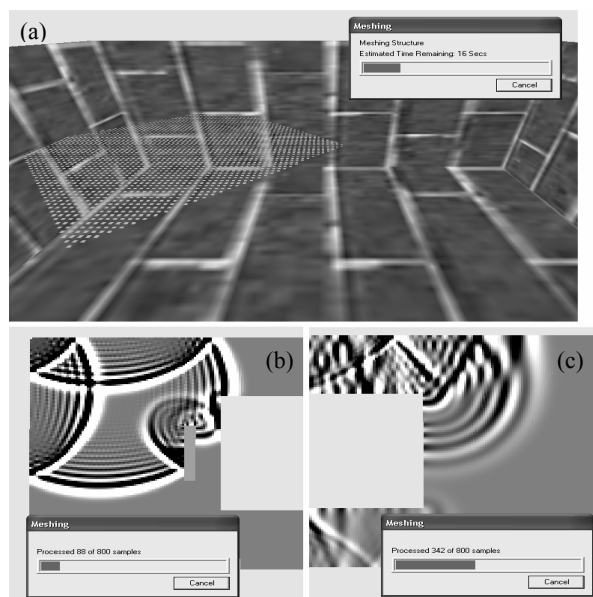

Figure 4: Meshing and Modelling - (a) populating a space with a bespoke mesh; (b) and (c) running a simulation - note the natural wavelike diffraction effects.

of angles in eight octave bands, plus diffusion coefficients for any number of surface sizes, again in eight octave bands.

3.1.3. Sources and Receivers

When satisfied with the geometry settings, *sources* and *receivers* are defined within the space. Again, the location and input/output properties of sources and receivers are defined in script files and are organized in a hierarchical manner. Sources and receivers may have geometry associated with them - for instance if a binaural response is required a model of a human can be inserted into the geometry set with virtual microphones placed at the ears [10]. RoomWeaver also offers input/output features for transducers, including auto-normalized output, resampling of input files to the mesh sampling rate, time delayed & signal-triggered sources plus individual channel gains for input and output signal files.

3.2. Running the Simulation

Once a virtual space has been defined the structure will need populating with a DWM, either 2D or 3D, together with the associated topologies and mesh types.

3.2.1. Creating the Mesh

RoomWeaver maps all mesh topologies to a rectangular array in the 2D case, or cubic array in the 3D case. The mesh array takes its size from the bounding box of the geometry. It is possible to rotate the geometry to create the smallest possible meshing volume. 2D meshes can exist along any plane within the geometry and can even be locked to key sources and receivers ensuring that the mesh intersects transducers of interest.

The choice of mesh topology available will depend on whether the mesh is 2D or 3D. Although certain topologies exhibit better dispersion characteristics than others, there will also be an associated implication on the efficiency of the RIR

generation algorithm. Once the topology is decided upon, a compatible mesh-type plug-in must be selected (ie. *Finite Difference* or *Wave-based*), and again mesh-types will vary in efficiency, quality and the types of geometry they can successfully deal with. RoomWeaver will only allow mesh-types that are appropriate for the chosen topology.

Meshes are grown to fit the room at simulation run-time using the selected topology plug-in. The mesh will grow from a user defined point in the room, with the meshing algorithm filling the modelled space with free-air type nodes until it encounters a surface. At these boundaries special boundary nodes are created that can take on the properties of the encountered surface - Figure 4(a). RoomWeaver also provides a tool to examine the meshing process. This is extremely useful for testing new topology plug-ins and checking the geometry for leaks if warning messages are reported.

3.2.2. Generation of Room Impulse Responses

The main variable set at simulation run-time is the mesh sample rate given by:

$$f_{update} = \frac{c\sqrt{N}}{d} \quad (1)$$

where c is the speed of sound, N is the dimension of the mesh and d is the inter-nodal distance. For example, for a 2D mesh with a target sample rate of 44.1 kHz, and $c = 343 \text{ ms}^{-1}$, an inter-nodal distance of 0.011 m is required. Ultimately this value of f_{update} will dictate the quality of the eventual output, with previous studies showing that a typical mesh gives a valid bandwidth only as far as $f_{update}/4$ [15]. However, large sample rates require exponentially denser meshes and hence use more computer memory and take longer to run. Other options at run time include setting a time or dB limit that, once reached, will terminate the modelling process. When the mesh is actually run the mesh-type plug-in is loaded and executed. The mesh nodes are created according to the plug-in specification and the algorithm will begin to generate RIR data for all of the active receivers present in the model. The impulse responses are stored as wave files in a unique file folder for each simulation run, preventing the user from accidentally overwriting previous RIR data.

Visualization options allow the user to choose to watch an animation of 2D or 3D meshes as they run as shown in Figure 4(b). This is useful for checking that the model is running as intended, observing wave behaviour and for testing mesh-type plug-ins, although visualization is processor intensive and will significantly slow down the simulation process. Due to the lengthy running time of these mesh models a function that enables room settings to be saved as *snapshots* is included, which stores all the present settings that affect the modelling process. These snapshots can be then be used to queue a sequence of simulations at run-time, allowing several simulations to be run overnight or at a weekend.

4. PLUG-IN CASE STUDY

To demonstrate the flexibility of RoomWeaver a short case study is presented that implements a new, efficient mesh type as a RoomWeaver plug-in.

4.1. The Hybrid Mesh & The KW-Pipe

Traditionally there have been two mesh types used in DWM simulations; the wave based scattering mesh and the finite difference (FD) mesh - a simplified formulation of the scattering equations. The scattering equations are derived from the 1D digital waveguide, where the sound pressure of a propagating wave signal at any given junction is defined as the sum of the input and the output to the node:

$$p_i = p_i^+ + p_i^- \quad (2)$$

Further, the sound pressure at a lossless scattering junction with N connected waveguides can be expressed as:

$$p_j = \frac{2 \sum_{i=1}^N \frac{p_i^+}{Z_i}}{\sum_{i=1}^N \frac{1}{Z_i}} \quad (3)$$

where p_i is the pressure in waveguide element i , Z_i is its associated impedance and p_j is the total pressure value at the scattering junction itself. As the waveguides are equivalent to bi-directional unit-delay lines, the input to a scattering junction is equal to the output from a neighbouring junction into the connecting waveguide at the previous time step:

$$p_{j,i}^+ = z^{-1} p_{i,j}^- \quad (4)$$

Using (2), (3), and (4) it is possible to derive an equivalent finite difference formulation for these scattering equations in terms of junction pressure values only:

$$p_j(n) = \frac{2}{N} \sum_{i=1}^N p_i(n-1) - p_j(n-2) \quad (5)$$

The FD mesh is the most computationally efficient, but boundary conditions are currently only simply implemented [16], limiting their application to basic rectangular geometries. The scattering mesh is the more flexible at a boundary, particularly when a triangular topology is used [16], and as such it is possible to design a mesh that will provide a better fit to a more irregular geometric structure. However meshes based on the scattering equations are more computationally inefficient and so it would clearly be useful if the speed and efficiency of the FD mesh could be combined with the enhanced flexibility of the scattering mesh. It is possible to interface these two mesh types using the KW-pipe adapter [17]. The KW pipe is an all-pass network that exhibits a time delay in one direction only, which allows finite difference elements to be seamlessly connected to scattering elements. It is termed 'KW' as scattering based nodes are often termed 'W' nodes and FD nodes are often termed as 'K' nodes.

By incorporating the KW-pipe into the scattering junction implementation a new "Black Box" scattering/KW-pipe junction is produced that looks identical to the finite difference version. These KW-Scattering junctions can be placed at the mesh boundaries where their geometrical flexibility is required, while the free-air nodes remain as regular FD nodes as shown in Figure 5. The free air nodes make up the overwhelming majority of the mesh, resulting in the significant speed and memory benefits of a purely FD based mesh together with the geometric and topological benefits of the scattering mesh.

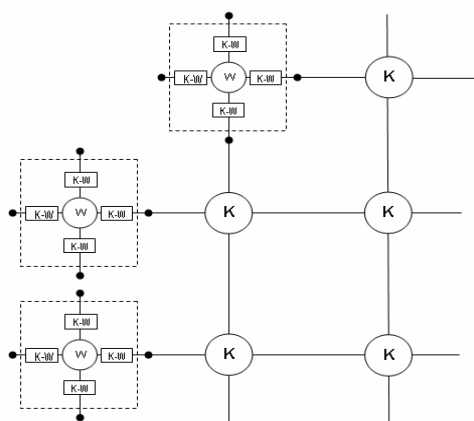

Figure 5: New boundary scattering junctions incorporating *K-W* pipes, giving them the external appearance of a Finite Difference junction.

4.2. Testing & Evaluating the Hybrid Mesh

To test these new mesh-types three simulations were conducted. A fan shaped room was selected due to its relatively simple acoustics and the fact that it is a non-rectangular geometry. Each simulation was conducted in 2D and used the same room with the following parameters.

- Dimensions – 10 m tall, 8 m at the bottom, 4 m at the top.
- 100% reflecting walls
- Mesh sample rate of 44.1 kHz.
- Sample rate sets waveguide size to 0.011 m
- Dimensions and waveguide size yield 260,330 nodes
- Sound source located towards the top center of the room
- Receiver located towards the bottom right of the room.

Each simulation evaluated the behaviour of a certain mesh type:

- Simulation 1 - standard Rectilinear Scattering Mesh,
- Simulation 2 - Rectilinear Hybrid Mesh
- Simulation 3 - Triangular Hybrid Mesh.

Visualizations of the hybrid models are shown in Figure 6. The ripples behind the wavefronts that have bounced off the side walls are due to discontinuities in the mesh as it tries to fit itself to the room geometry. This effect is less pronounced in the hybrid triangular mesh as its additional connections allow it to fit more accurately to the actual room geometry.

Figure 7 shows a spectral analysis (up to 500 Hz) of the output signals from the rectilinear scattering and rectilinear hybrid meshes and highlights the accurate low frequency response of both the scattering and hybrid DWM models. The axial mode at 16 Hz between the parallel top and bottom walls is clearly visible in both responses. It is interesting to note that the modes from the hybrid mesh are more pronounced in amplitude than those of the scattering mesh. One explanation for this is that it is easier to excite the hybrid mesh with a broadband signal as an unfortunate property of the scattering equations is that input signals get distorted due to an imbalance of incoming and outgoing energy at the excited node (See equation (3)).

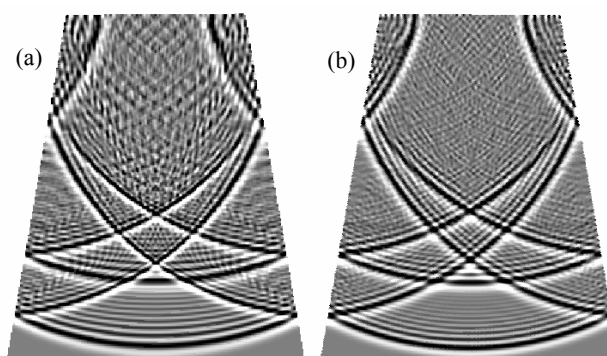

Figure 6: Run time visualizations: (a) A rectilinear topology showing dispersion and distorted reflections. (b) A triangular hybrid topology showing better dispersion characteristics and cleaner reflections from the side walls.

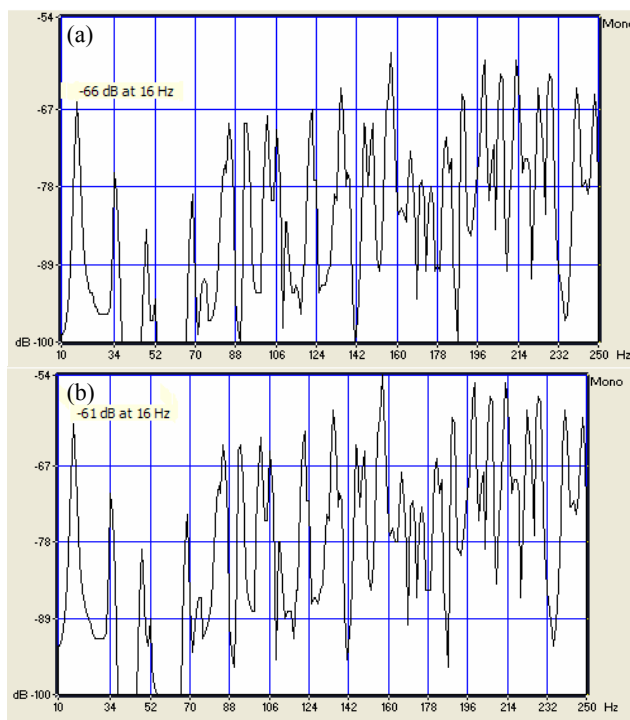

Figure 7: Low Frequency Response of (a) The Wave-Based Mesh and (b) The new Hybrid Mesh.

An experiment was conducted to evaluate the improvements of the hybrid mesh in terms of processing time and memory requirements. The results were achieved on a PC with a 2.88 GHz P4 processor and 512 MB of RAM. A speed increase of 200% and memory usage decrease of 50% was observed when using the Hybrid rectilinear over the scattering rectilinear mesh. RoomWeaver makes obtaining such data simple as it reports the time taken to run a mesh and how much memory it is allocating to the mesh.

5. CONCLUSIONS

This paper helps to establish DWM models as an alternative and viable means to generating virtual RIRs for an enclosed acoustic space over more traditional methods. The RoomWeaver system has been presented and been demonstrated as a useful acoustical research tool, allowing DWM models to be applied to more complex room geometries than those previously investigated, resulting in the acquisition of valid virtual RIRs suitable for a variety of auralization applications. The introduction and implementation of the hybrid mesh based on the KW-pipe demonstrates that RoomWeaver has potential as a valuable and extensible research tool, making the development of new DWM techniques quick and easy. Future work will focus on expanding the current portfolio of mesh-types and implementing improved boundaries that are currently being developed in a parallel study.

6. ACKNOWLEDGEMENTS

This work is supported by the UK Engineering and Physical Sciences Research Council (EPSRC), Grant Number GR/S01481/01 and in part by the Swedish Foundation for International Cooperation in Research and Higher Education (STINT), contract IG2002-2049.

7. REFERENCES

- [1] C. L. Christensen, "Odeon – A Design Tool for Auditorium Acoustics, Noise Control and Loudspeaker Systems," *Proc. of Inst. of Acoustics, Reproduced Sound 17*, pp. 127–144, vol. 23, no. 8, Stratford-upon-Avon, UK, Nov. 2001. See also - <http://www.odeon.dk/> (Current, July 2004).
- [2] A. James, A. Naqvi & D. I. Dalenbäck, "Computer Modelling with CATT-Acoustic: Theory & Practice of Diffuse Reflection & Array Modelling," *Proc. of Inst. of Acoustics, Reproduced Sound 17*, vol. 23, no. 8, Stratford-upon-Avon, UK, Nov. 2001. See also - <http://www.catt.se/> (Current, July 2004).
- [3] U. Stephenson, "Comparison of the Image Source Method & the Particle Simulation Method," *Applied Acoustics*, no. 29, pp. 35–72, 1990.
- [4] A. Krokstad, S. Strøm, and S. Srósdal, "Calculating the Acoustical Room Response by use of a Ray Tracing Technique," *J. of Sound Vibration*, vol. 8, no. 1, pp. 118–125, 1968.
- [5] A. Farina, "Pyramid Tracing Vs Ray Tracing for the Simulation of Sound Propagation in Large Rooms," *Computational Acoustics and its Environmental Applications*, pp. 109–116, Computational Mechanics Publications, Southampton, UK, 1995.
- [6] J. R. Wright, "An Exact Model of Acoustic Radiation in Enclosed Spaces," *J. of the AES*, vol. 43, no. 5, pp. 813–820, Oct 1995.
- [7] L. Savioja, T. J. Rinne, and T. Takala, "Simulation of Room Acoustics with a 3-D Finite Difference Mesh," *Proc. of the Int. Computer Music Conf (ICMC)*, pp. 463–466, Denmark, 1994.
- [8] D. T. Murphy and D. M. Howard, "2-D Digital Waveguide Mesh Topologies in Room Acoustics Modelling," *Proc. of the 3rd Int. Conf. on Digital Audio Effects (DAFX-00)*, pp. 211–216, Verona, Italy, Dec. 2000.
- [9] G. Campos and D. M. Howard, "A Parallel 3-D Digital Waveguide Mesh Model with Tetrahedral Topology for Room Acoustic Simulation", *Proc. of DAFX-00*, pp. 73–78, Verona, Italy, Dec. 2000.
- [10] D. T. Murphy and M. J. Beeson, "Modelling Spatial Sound Occlusion and Diffraction Effects with the Digital Waveguide Mesh," *Proc. of the 24th AES Int. Conf.*, pp. 207–216, Banff, Canada, June 2003.
- [11] J. O. Smith, "Physical Modelling using Digital Waveguides," *Computer Music Journal*, vol. 16, no. 4, pp. 74–87, 1992.
- [12] S. A. Van Duyne and J. O. Smith III, "The 3D Tetrahedral Digital Waveguide Mesh with Musical Applications," *Proc. of the ICMC*, pp. 9–16, Hong Kong, 1996.
- [13] L. Savioja and V. Välimäki, "Reducing the dispersion error in the digital waveguide mesh using interpolation and frequency warping techniques," *IEEE Trans. Speech and Audio Processing*, vol. 8, pp. 184–194, March 2000.
- [14] A. Kelloniemi, D. T. Murphy, L. Savioja, and V. Välimäki, "Boundary Conditions in a Multi-dimensional Digital Waveguide Mesh," *Proc. of IEEE ICASSP*, Montreal, Canada, May 17–21, 2004.
- [15] S. Van Duyne and J. O. Smith, "The 2-D digital waveguide-mesh," *Proc. of ICMC*, pp. 40–47, Tokyo, 1993.
- [16] F. Fontana, *Physics-based models for the acoustic representation of space in virtual environments*, Unpublished Ph.D. Thesis, Apr. 2003.
- [17] M. Karjalainen, "Mixed Physical Modelling: DWG + FDTD + WDF," *Proc. of IEEE WASPAA*, New Paltz, New York, Oct. 2003.